

# HD SRV5U SLATE ROOF VENT

## Fixing Instructions

Designed as a 600 x 300mm slate size replacement and can be trimmed to suit 500 x 250mm slates.

### HD SRV5U SLATE ROOF VENT

1. Once the position has been selected, mark on the batten the course the slate vent is to be fitted to. Proceed to slate the roof to comply to manufacturer's specification until you reach the course immediately below the location selected for the slate vent to be fitted.

2. Remove equal sized corners from the two slates directly beneath the vent by cutting diagonally from a point 150mm across the top of each slate to a meeting point 230mm down the slate thereby creating a triangle pointing down the roof. Fig 1

3. Cut an upside down 'T' shape in the roofing underlay from the bottom edge of the top batten. Fold the triangular shape flaps outwards under the vent to deflect and prevent water and debris penetration through the roof underlay. Fig 2

4. Fit the vent as per a normal slate. When using either natural or man-made slates, secure the tail of the vent with a copper disc rivet through the hole provided.

5. The base of the vent may be trimmed along the 'trim lines' on the underside to suit 500 x 250mm slates.

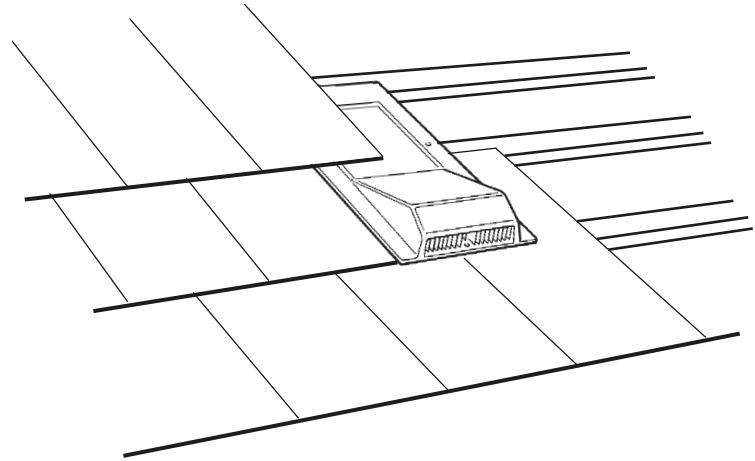
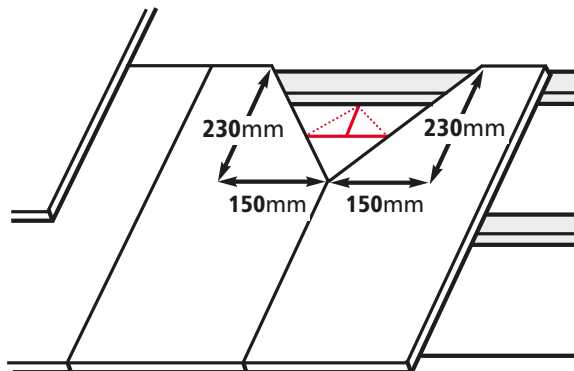

Fig 1



**Note:** When cutting the slates and underlay it is important to ensure that the opening in the roof aligns with the opening on the underside of the vent.

Fig 2

For further advice on the fitting of this product, or any other technical information please contact:

Hambleside Danelaw Ltd,  
Long March, Daventry,  
Northamptonshire  
NN11 4NR

01327 701910  
techelp@hambleside-danelaw.co.uk  
www.hambleside-danelaw.co.uk

